

NEW! AIR PREPARATION EQUIPMENT

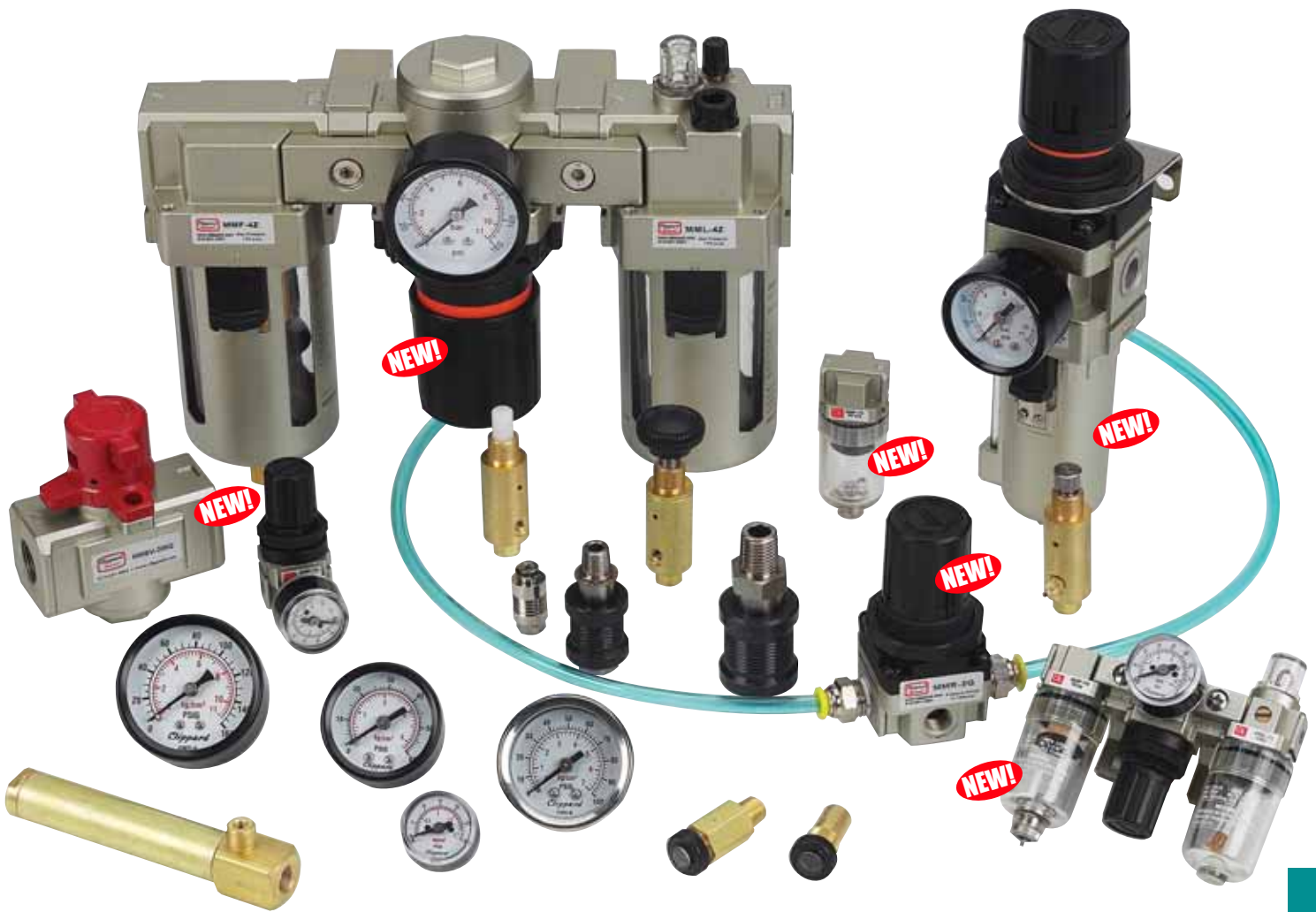

NEW! MAXIMATIC® FILTER-REGULATOR-LUBRICATORS	340 - 343
NEW! MAXIMATIC® FILTER-REGULATORS	344
NEW! MAXIMATIC® FILTERS	345
NEW! MAXIMATIC® REGULATORS	346
2- & 3-WAY SLEEVE/SHUT-OFF VALVES	346, 356, 357
NEW! MAXIMATIC® LUBRICATORS	347
NEW! MAXIMATIC® MOUNTING HARDWARE	348 - 350
GAUGES	351
NEW! MAXIMATIC® FLOW CHARTS	352 - 355





NEW! MAXIMATIC® FILTER-REGULATOR-LUBRICATORS



Maximatic Filters, Regulators & Lubricators

Maximatic FRLs condition and prepare compressed air for use in fluid power systems. Pneumatic applications with properly conditioned air will operate longer, cost less and improve system efficiency. Clippard offers five different sizes from #10-32 to 1" NPT of Filter, Regulators, Lubricators and combination units. Their modular design and interconnecting brackets provide flexibility and facilitates simple field installation and/or modification.

Filters. Filters capture solid particulate and remove water by "spinning" the air centrifugally. Water and larger particles are thrown against the side of the bowl where they condense and/or fall to the lower part of the bowl. Smaller particles are captured as the air flows through the filter element.

Regulators. Controlling pressure is an important requirement in all systems. Maximatic Regulators are adjustable from 7 to 125 psig. For applications requiring better resolution, 7 to 30 or 7 to 60 psig models with spring are available. The #10-32 size is a piston-style due to its small size, while the 1/8" to 1" are a diaphragm design. Both types feature a poppet-type inlet valve which enables free reverse flow when the inlet air is removed.

Lubricators. Pneumatic actuators and valves perform better and last longer when properly lubricated. The bowl serves as a reservoir for the oil and supplies oil through the pick-up tube when pressurized. The amount of oil dispersed is controlled by an adjustable needle valve as well as the flow rate through the lubricator.

- Body Material:** Die Cast Aluminum
- Maximum Operating Pressure:** 150 psig
- Regulating Range:** 125 psig standard, 30 psig and 60 psig optional
- Regulator Type:** Relieving
- Filter Drain:** Semi-Automatic Differential or Optional Automatic Drain. When the air supply is below 7 psig, the semi-automatic drain will open.
- Bowl Material:** Polycarbonate standard up to 4Z model/size. Metal bowl standard on 4A and 5B models/sizes. Aluminum Cast with sight glass available.
- Bowl Guard:** Steel on models indicated
- Filtration:** 25 micron sintered brass filter standard, 5 micron optional
- Temperature Range:** 32° to 130°F (-0 to 54°C)

Ordering Guide

Type	Enter	Type	Enter
FRL	.FRL	Filter	.F
Stacking FRL	.FRLS	Regulator	.R
Stacking Filter-Regulator	.FRS	Lubricator	.L

Body/Port Size	Enter	Body/Port Size	Enter
#10-32	.1N	3/8" NPT (High Flow)	.4W
1/8" NPT	.2P	1/2" NPT	.4Z
1/4" NPT (Standard Flow)	.2Q	3/4" NPT	.4A
1/4" NPT (High Flow)	.3Q	1" NPT	.5B
3/8" NPT (Standard Flow)	.3W		

Options	Automatic Drain (D)	Metal Bowl (M)	30 psig (P30)	60 psig (P60)	5 Micron Filter (F5)
	<input type="checkbox"/>	<input type="checkbox"/>	<input type="checkbox"/>	<input type="checkbox"/>	<input type="checkbox"/>

This numbering schematic is shown for illustration purposes only. All possible configurations are not available—For standard models, see the products illustrated in this catalog.

Example: MM - -

MM - -

NEW! MAXIMATIC® FILTER-REGULATOR-LUBRICATORS



#10-32 through 1" NPT ports available

Large selection of convenient mounting hardware offered

All FRL components are a modular design which allow easy connection and disconnection of the components for simple installation and maintenance.

Pressure Gauge allows for easy viewing

Die Cast Aluminum Body

Easy-to-view sight glasses standard on all metal bowls

Flow rates from 3 scfm to 280 scfm

Lubricators increase component life by dispensing oil into the airline supply

25 micron filters standard, 5 micron optional

Filters prevent moisture and solid particulates from getting into compressed air lines

Semi-Automatic or Automatic Drain

Regulator ensures a constant downstream air line pressure



Bowl Shield

Polycarbonate bowls are standard on all filters and lubricators. Bowl shields are standard on MMF/MML 4A and 5B. An optional metal bowl is available for filters and lubricators.



Metal Bowl



NEW! MAXIMATIC® FILTER-REGULATOR-LUBRICATORS



MMFRL-2P-D
FRL with Polycarbonate Bowls
and Auto Drain



MMFRL-3W
FRL with Bowl Shields

Combination FRLs provide air filtration, regulation and lubrication in one unit for easy mounting and installation. Includes L brackets and gauge.

Bowl: Polycarbonate standard. Steel bowl shields provided on models indicated. Metal bowls with sight glasses also available, add "-M" to the Part Number.

Regulating Range: 7 to 100 psig on MMFRL-1N, 7 to 125 psig on all others. 30 and 60 psig ranges also available, add "-P30" or "-P60" to the end of the Part Number.

Drain: Semi-Automatic standard on MMFRLS-3 series. Manual standard on all others. Optional Automatic Drain

available—add "-D" to the Part Number. Drains not available on Lubricators.

Filtration: 25 micron filter standard. Add "-F5" to the end of the Part Number for an optional 5 micron filter.

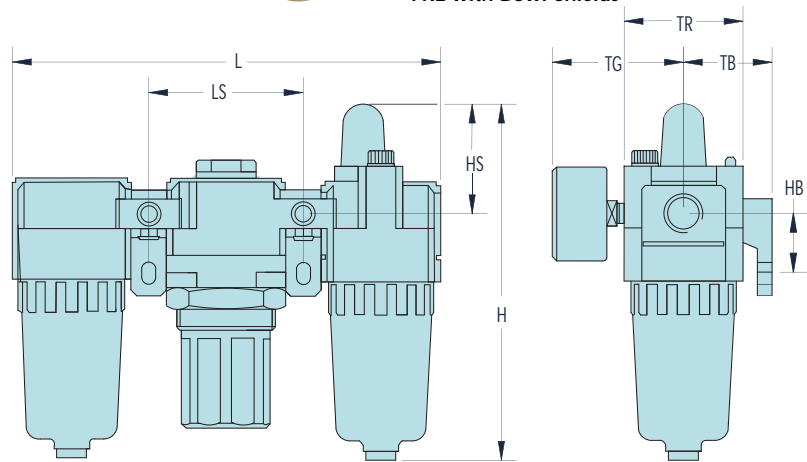

Drawing shown with Polycarbonate Bowl without Shield or Auto Drain

Dim.	MMFRL-4Z					
	MMFRL-1	MMFRL-2	MMFRL-3	MMFRL-4W	MMFRL-4A	MMFRL-5B
H	3.33 (84.6)	4.92 (125.0)	6.16 (156.5)	7.54 (191.5)	7.60 (193.0)	10.69 (271.5)
HB	0.79 (20.1)	0.94 (23.9)	1.39 (35.3)	1.57 (40.0)	1.57 (39.9)	1.97 (50.0)
HS	1.00 (25.4)	1.50 (38.1)	1.50 (38.1)	1.61 (40.9)	1.61 (40.9)	1.89 (48.0)
L	3.58 (90.9)	5.51 (140.0)	7.13 (181.1)	9.37 (238.0)	9.96 (253.0)	11.81 (300.0)
LS	1.3 (33.0)	1.97 (50.0)	2.52 (64.0)	3.31 (84.1)	3.50 (88.9)	4.13 (104.9)
TB	0.98 (24.9)	1.18 (30.0)	1.61 (41.0)	1.97 (50.0)	1.97 (50.0)	2.75 (69.9)
TG	1.02 (25.9)	2.24 (57.0)	2.39 (60.7)	2.58 (65.5)	2.74 (69.6)	2.97 (75.4)
TR	0.98 (24.9)	1.57 (40.0)	2.09 (53.1)	2.76 (70.1)	2.76 (70.1)	3.54 (89.9)

Part No.	Port	Gauge Port	Flow Rate	Bowl Shield	Gauge
MMFRL-1N	#10-32	1/16" NPT	3 scfm	no	PG-10-160J
MMFRL-2P	1/8" NPT	1/8" NPT	18 scfm	no	PG-15-160P
MMFRL-2Q	1/4" NPT	1/8" NPT	18 scfm	no	PG-15-160P
MMFRL-3Q	1/4" NPT	1/8" NPT	70 scfm	yes	PG-15-160P
MMFRL-3W	3/8" NPT	1/8" NPT	70 scfm	yes	PG-15-160P
MMFRL-4W	3/8" NPT	1/4" NPT	140 scfm	yes	PG-15-160P
MMFRL-4Z	1/2" NPT	1/4" NPT	140 scfm	yes	PG-20-160Q
MMFRL-4A-M*	3/4" NPT	1/4" NPT	160 scfm	yes	PG-20-160Q
MMFRL-5B-M*	1" NPT	1/4" NPT	180 scfm	yes	PG-20-160Q

* Metal bowl standard

NEW! MAXIMATIC® STACKING FRLS



MMFRLS-2Q-D
Stacking FRL with
Polycarbonate Bowls
and Auto Drain



MMFRLS-3Q-D
Stacking FRL with Bowl
Shields and Auto Drain



Stacking FRLs provide air filtration, regulation and lubrication in one unit for easy mounting and installation.

- Includes L bracket and gauge

Bowl: Polycarbonate standard. Steel shield provided on models indicated. Metal bowls with sight gauges also available, add "-M" to the end of the Part Number.

Regulating Range: 7 to 100 psig on MMFRLS-1N, 7 to 125 psig on all others. 30 and 60 psig ranges also available, add "-P30" or "-P60" to the end of the Part Number.

Drain: Semi-Automatic standard on MMFRLS-3/4/5 series. Manual standard on all others. Optional Automatic Drain available—add "-D" to Part Number.

Filtration: 25 micron filter standard. Add "-F5" to the end of the Part Number for an optional 5 micron filter.

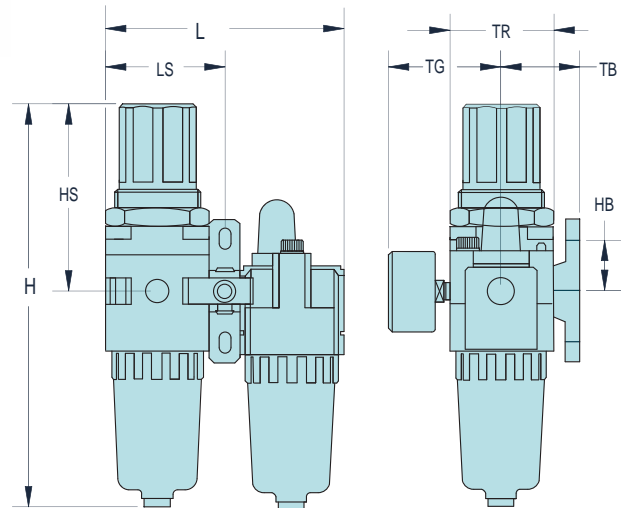

Drawing shown
without Shield
or Auto Drain

Dim.	MMFRLS-1	MMFRLS-2	MMFRLS-3	MMFRLS-4Z		
				MMFRLS-4W	MMFRLS-4A	MMFRLS-5B
H	4.31 (109.5)	6.48 (164.6)	8.31 (211.1)	10.31 (261.9)	10.51 (267.0)	13.31 (338.1)
HB	0.79 (20.1)	0.94 (23.9)	1.38 (35.1)	1.57 (39.9)	1.57 (39.9)	1.97 (50.0)
HS	1.99 (50.5)	3.07 (78.0)	3.64 (92.5)	4.41 (112.0)	4.49 (114.0)	4.57 (116.1)
L	2.28 (57.9)	3.54 (89.9)	4.61 (117.1)	6.06 (153.9)	6.46 (164.1)	7.68 (195.1)
LS	1.14 (29.0)	1.77 (45.0)	2.30 (58.4)	3.03 (77.0)	3.23 (82.0)	3.84 (97.5)
TB	0.98 (24.9)	1.18 (30.0)	1.61 (40.9)	1.97 (50.0)	1.97 (50.0)	2.75 (69.9)
TG	1.02 (25.9)	2.24 (56.9)	2.39 (60.7)	2.58 (65.5)	2.74 (69.6)	2.97 (75.4)
TR	0.98 (24.9)	1.57 (39.9)	2.09 (53.1)	2.76 (70.1)	2.76 (70.1)	3.54 (89.9)

Part No.	Port	Gauge Port	Flow Rate		Bowl Shield	Gauge
MMFRLS-1N	#10-32	1/8" NPT	3 scfm	90 l/min	no	PG-10-160J
MMFRLS-2P	1/8" NPT	1/8" NPT	18 scfm	500 l/min	no	PG-15-160P
MMFRLS-2Q	1/4" NPT	1/8" NPT	18 scfm	500 l/min	no	PG-15-160P
MMFRLS-3Q	1/4" NPT	1/8" NPT	60 scfm	1,700 l/min	yes	PG-15-160P
MMFRLS-3W	3/8" NPT	1/8" NPT	60 scfm	1,700 l/min	yes	PG-15-160P
MMFRLS-4W	3/8" NPT	1/4" NPT	105 scfm	3,000 l/min	yes	PG-20-160Q
MMFRLS-4Z	1/2" NPT	1/4" NPT	105 scfm	3,000 l/min	yes	PG-20-160Q
MMFRLS-4A-M*	3/4" NPT	1/4" NPT	140 scfm	4,000 l/min	yes	PG-20-160Q
MMFRLS-5B-M*	1" NPT	1/4" NPT	180 scfm	5,000 l/min	yes	PG-20-160Q

* Metal bowl standard



NEW! MAXIMATIC® STACKING FILTER-REGULATORS



MMFRS-3Q
Stacking Filter-Regulator
with Bowl Shield & Semi-
Automatic Drain



MMFRS-2P
Stacking Filter-Regulator
with Polycarbonate Bowl
& Manual Drain



Stacking Filter-Regulator combinations provide air filtration and precise regulation in a single unit for easy mounting and installation where space is limited.

- Includes bracket and gauge (see Page 346 for dimensions).

Regulating Range: 7 to 100 psig on MMFRS-1N, 7 to 125 psig on all others. 30 and 60 psig ranges also available, add "-P30" or "-P60" to the end of the Part Number.

Bowl: Polycarbonate standard. Steel bowl shield provided on models indicated. Metal bowl with sight gauge also available, add "-M" to the Part Number.

Differential Drain: Semi-Automatic standard on MMFRS-3/4/5 series; Manual standard on all other models. When supply pressure is below 7 psig on all MMFRS-3 and MMFRS-4 models without metal bowls, the standard drain will open. An optional Automatic Drain available—add "-D" to Part Number.

Filtration: 25 micron filter standard. Add "-F5" to the end of the Part Number for an optional 5 micron filter.

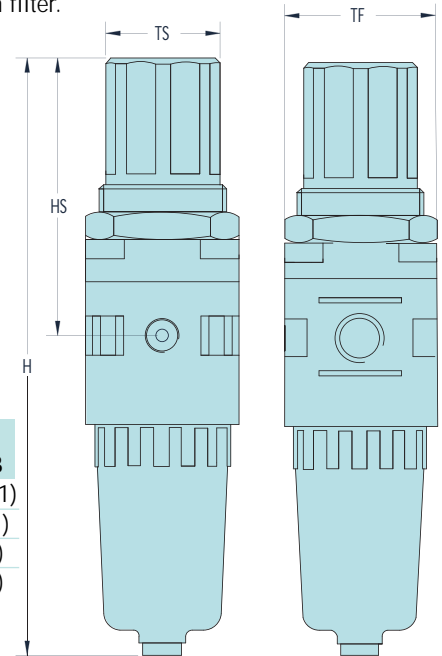

	MMFRS-1N	MMFRS-2Q	MMFRS-3W	MMFRS-4Z	MMFRS-4A	MMFRS-5B
Dim.						
H	4.31 (109.5)	6.48 (164.6)	8.31 (211.0)	10.31 (261.9)	10.51 (267.0)	13.31 (338.1)
HS	1.99 (50.5)	3.07 (78.0)	3.64 (92.5)	4.41 (112.0)	4.49 (114.0)	4.57 (116.1)
TF	0.98 (24.9)	1.57 (39.9)	2.09 (53.1)	2.76 (70.1)	2.76 (70.1)	3.54 (89.9)
TS	1.10 (27.9)	1.34 (34.0)	1.37 (40.0)	2.13 (54.1)	2.13 (54.1)	2.13 (54.1)

Part No.	Port	Gauge Port	Flow Rate	Bowl Shield	Gauge
MMFRS-1N	#10-32	1/16" NPT	3 scfm	no	PG-10-160J
MMFRS-2P	1/8" NPT	1/8" NPT	19 scfm	no	PG-15-160P
MMFRS-2Q	1/4" NPT	1/8" NPT	19 scfm	no	PG-15-160P
MMFRS-3Q	1/4" NPT	1/8" NPT	70 scfm	yes	PG-15-160P
MMFRS-3W	3/8" NPT	1/8" NPT	70 scfm	yes	PG-15-160P
MMFRS-4W	3/8" NPT	1/4" NPT	140 scfm	yes	PG-20-160Q
MMFRS-4Z	1/2" NPT	1/4" NPT	140 scfm	yes	PG-20-160Q
MMFRS-4A-M*	3/4" NPT	1/4" NPT	160 scfm	yes	PG-20-160Q
MMFRS-5B-M*	1" NPT	1/4" NPT	195 scfm	yes	PG-20-160Q

* Metal bowl standard

NEW! MAXIMATIC® FILTERS



Maximatic® filters remove moisture and contaminants, and provide air filtration through a 25 micron filter. Replacement 25 micron and 5 micron filters are available.

- Semi-automatic drain standard on MMFRLS-3/4/5 series. Manual drain standard on all others. Optional Automatic Drain available—add “-D” to Part Number.

Bowl: Polycarbonate standard. Cast steel shield provided on models indicated. Metal bowl with sight gauge also available, add “-M” to the end of the Part Number.

Filtration: 25 micron filter standard. Add “-F5” to Part Number for optional 5 micron filter.

Filter	F	H	HS	TF
MMF-1	--	2.60 (66.0)	0.28 (7.1)	0.98 (24.9)
MMF-2	1.81 (50.0)	3.84 (97.5)	0.43 (10.9)	1.57 (39.9)
MMF-3	2.26 (57.4)	5.22 (132.6)	0.55 (14.0)	2.09 (53.1)
MMF-4W/4Z	3.00 (76.2)	6.63 (168.4)	0.71 (18.0)	2.76 (70.1)
MMF-4A-M	3.00 (76.2)	6.79 (172.5)	0.79 (19.8)	2.76 (70.1)
MMF-5B-M	3.00 (76.2)	9.74 (247.4)	0.94 (23.9)	3.54 (89.9)

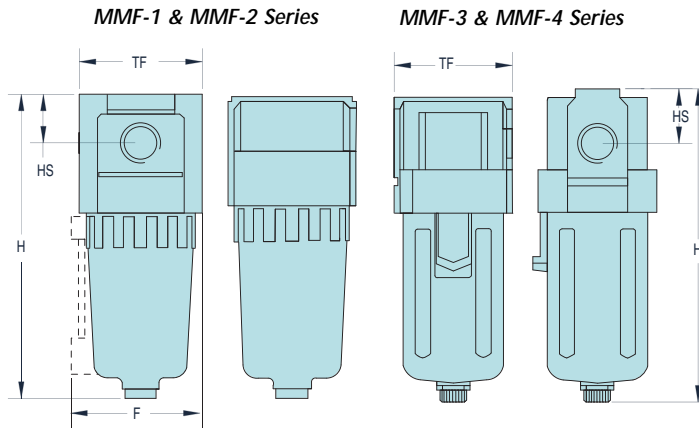

MAXIMUM
Value. →
→ Performance.

Part No.	Port	Flow Rate	Bowl Shield
MMF-1N	#10-32	4 scfm	no
MMF-2P	1/8" NPT	26 scfm	no
MMF-2Q	1/4" NPT	26 scfm	no
MMF-3Q	1/4" NPT	70 scfm	2,000 l/min
MMF-3W	3/8" NPT	70 scfm	2,000 l/min
MMF-4W	3/8" NPT	140 scfm	4,000 l/min
MMF-4Z	1/2" NPT	140 scfm	4,000 l/min
MMF-4A-M*	3/4" NPT	210 scfm	6,000 l/min
MMF-5B-M*	1" NPT	245 scfm	7,000 l/min

* Metal bowl standard



NEW! MAXIMATIC® REGULATORS

Maximatic® Regulators provide precise air regulation from 7 to 125 psig. The adjustment knob must be pulled out to adjust the pressure, preventing accidental adjustment. Maximum inlet pressure is 150 psig. Includes bracket and gauge.

Regulating Range: 7 to 100 psig standard on MMR-1N, and 7 to 125 psig on all others. 30 and 60 psig ranges also available, add "-P30" or "-P60" to the end of the Part Number.



Dim.	MMR-4Z					
	MMR-1	MMR-2	MMR-3	MMR-4W	MMR-4A	MMR-5
H	2.42 (61.5)	3.74 (95.0)	5.02 (127.5)	5.89 (149.6)	6.06 (153.9)	6.61 (168.0)
HS	0.43 (10.9)	0.67 (17.0)	1.38 (35.0)	1.48 (37.6)	1.59 (40.4)	1.89 (47.3)
HC	1.12 (28.4)	1.86 (47.2)	2.26 (57.4)	2.78 (70.6)	2.78 (70.6)	2.83 (71.9)
HN	0.75 (19.1)	1.00 (25.4)	1.25 (31.8)	1.44 (36.6)	1.44 (36.6)	1.87 (47.5)
HI	0.43 (10.9)	0.65 (16.5)	1.32 (33.5)	1.43 (36.3)	1.43 (36.3)	1.70 (43.2)
TF	0.98 (24.9)	1.57 (39.9)	2.09 (53.1)	2.76 (70.1)	2.76 (70.1)	3.54 (89.9)
TS	1.10 (27.4)	1.34 (34.0)	1.57 (39.9)	2.13 (54.1)	2.13 (54.1)	2.13 (54.1)

Part No.	Port	Gauge Port	Flow Rate		Gauge
MMR-1N	#10-32	1/16" NPT	4 scfm	100 l/min	PG-10-160J
MMR-2P	1/8" NPT	1/8" NPT	19 scfm	550 l/min	PG-15-160P
MMR-2Q	1/4" NPT	1/8" NPT	19 scfm	550 l/min	PG-15-160P
MMR-3Q	1/4" NPT	1/8" NPT	88 scfm	2,500 l/min	PG-15-160P
MMR-3W	3/8" NPT	1/4" NPT	88 scfm	2,500 l/min	PG-15-160P
MMR-4W	3/8" NPT	1/4" NPT	140 scfm	4,000 l/min	PG-20-160Q
MMR-4Z	1/2" NPT	1/4" NPT	140 scfm	4,000 l/min	PG-20-160Q
MMR-4A	3/4" NPT	1/4" NPT	210 scfm	6,000 l/min	PG-20-160Q
MMR-5A	3/4" NPT	1/4" NPT	280 scfm	8,000 l/min	PG-20-160Q
MMR-5B	1" NPT	1/4" NPT	280 scfm	8,000 l/min	PG-20-160Q

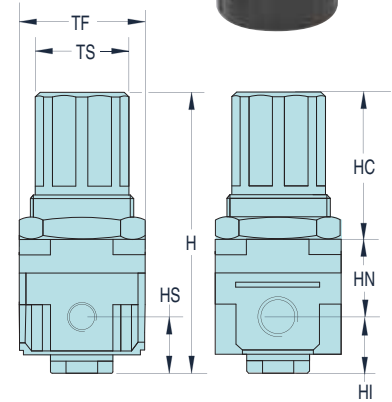

NEW! RELIEVING SHUT-OFF/LOCK OUT VALVES

Maximatic Shut-Off/Lock Out valves may be used in conjunction with Maximatic FRLs to provide a method of turning off the air supply. Cleaning or replacing filters, adding oil to the lubricator or other maintenance steps can be made without the air supply present. The valve can also be locked in the "off" position (lock not provided) to prevent accidental pressurizing.

Medium: Air
Input Pressure: 150 psig

Air Flow: See table below
Mounting: In-line

Material: Die Cast Aluminum

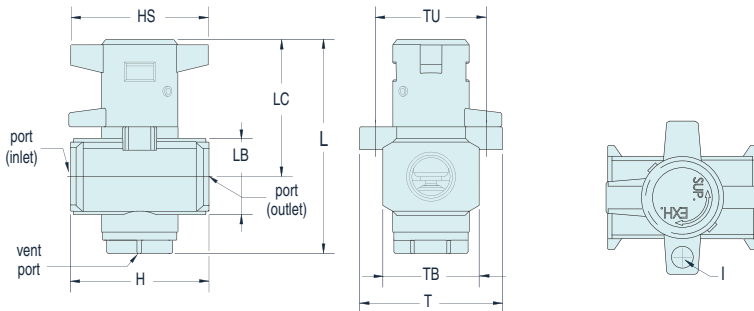

Dim.	MMSV-3QP	MMSV-3WQ	MMSV-3ZW
	MMSV-3PP	MMSV-3QQ	MMSV-3WW
L	2.44 (62.0)	3.07 (78.0)	3.32 (84.3)
H	1.58 (40.1)	2.09 (53.1)	2.76 (70.1)
TB	1.10 (27.9)	1.18 (30.0)	1.42 (36.1)
T	1.62 (41.1)	2.10 (53.3)	2.10 (53.3)
TU	1.26 (32.0)	1.63 (41.4)	1.63 (41.4)
LC	1.57 (39.9)	1.95 (49.5)	2.08 (52.8)
LB	0.87 (22.1)	1.10 (27.9)	1.42 (36.1)
HS	1.58 (40.1)	1.77 (45.0)	1.77 (45.0)
I	0.24 (10.2)	0.29 (7.4)	0.29 (7.4)

Part No.	Port	Vent Port	Air Flow (cfm) @ 100 psig	For Use with FRL, Filter-Regulator, Filter & Regulator Series:					
				MMFRL-2	MMFRLS-2	MMFR-2	MMFRS-2	MMF-2	MMR-2
MMSV-3PP	1/8" NPT	1/8" NPT	18						
MMSV-3QP	1/4" NPT	1/8" NPT	25						
MMSV-3QQ	1/4" NPT	1/4" NPT	60						
MMSV-3WQ	3/8" NPT	1/4" NPT	90						
MMSV-3WW	3/8" NPT	3/8" NPT	120						
MMSV-3ZW	1/2" NPT	3/8" NPT	180						

NEW! MAXIMATIC® LUBRICATORS



MML-3W
Lubricator with
Bowl Shield



MML-2P
Lubricator with
Polycarbonate
Bowl



MML-2Q-M
Lubricator with
Metal Bowl

These inexpensive direct-flow lubricators provide lubrication to downstream valves and actuators

Bowl: Polycarbonate standard. Steel Shield provided on models as indicated. Metal bowl with sight glass also available, add "-M" to the Part Number.



Mounting Hardware

For a complete offering of mounting hardware, spacers, replacement bowls and other accessories, see pages 348 through 350.

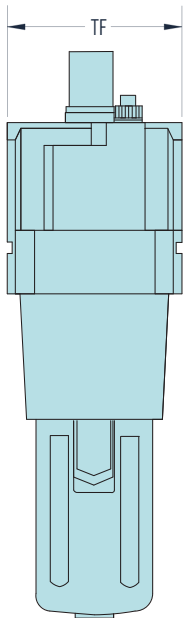

MML-3, MML-4 & MML-5 Series

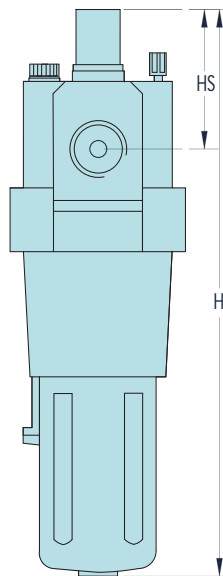

MML-1 & MML-2 Series

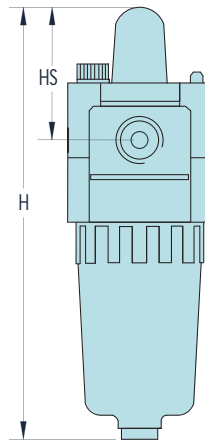

Lubricator Bowl Fluid Capacity		
Model	Bowl #	Capacity
MML-2	27057-2	0.8 oz./24 ml (cc)
MML-3	27058-3	2.3 oz./68 ml (cc)
MML-4	27058-4	6.2 oz./183 ml (cc)

Part No.	Port	Flow Rate		Bowl Shield	Dimensions		
					H	HS	TF
MML-1N	#10-32	3 scfm	90 l/min	no	3.21 (81.5)	1.00 (25.4)	0.98 (24.9)
MML-2P	1/8" NPT	28 scfm	800 l/min	no	4.80 (121.9)	1.50 (38.1)	1.57 (39.9)
MML-2Q	1/4" NPT	28 scfm	800 l/min	no	4.80 (121.9)	1.50 (38.1)	1.57 (39.9)
MML-3Q	1/4" NPT	60 scfm	1,700 l/min	yes	5.59 (142.0)	1.50 (38.1)	2.09 (53.1)
MML-3W	3/8" NPT	60 scfm	1,700 l/min	yes	5.59 (142.0)	1.50 (38.1)	2.09 (53.1)
MML-4W	3/8" NPT	180 scfm	5,000 l/min	yes	6.97 (177.0)	1.61 (40.9)	2.76 (70.1)
MML-4Z	1/2" NPT	180 scfm	5,000 l/min	yes	6.97 (177.0)	1.61 (40.9)	2.76 (70.1)
MML-4A	3/4" NPT	220 scfm	6,300 l/min	yes	6.97 (177.0)	1.54 (39.1)	2.76 (70.1)
MML-5B	1" NPT	245 scfm	7,000 l/min	yes	10.00 (254.0)	1.77 (45.0)	3.54 (89.9)



NEW! MAXIMATIC® MOUNTING HARDWARE

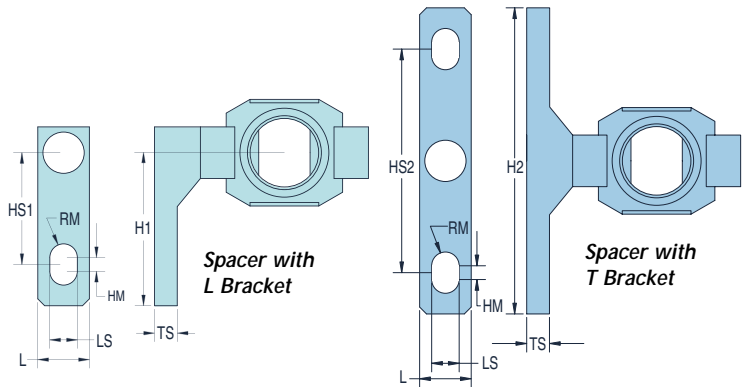
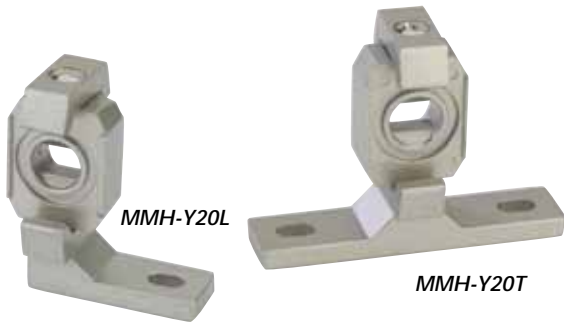

Mounting Hardware for Combination Units

To convert individual Filter, Regulator and Lubricators into combination units. Seals included.

FRL Series	Spacer with L Bracket	Spacer with T Bracket	Dim.	MMH-Y10L MMH-Y10T	MMH-Y20L MMH-Y20T	MMH-Y30L MMH-Y30T	MMH-Y40L MMH-Y40T	MMH-Y50L MMH-Y50T	MMH-Y60L MMH-Y60T
FRL-1	MMH-Y10L	MMH-Y10T	L	0.47 (12.0)	0.59 (15.0)	0.63 (16.0)	0.87 (22.0)	0.87 (22.0)	0.91 (23.0)
FRL-2	MMH-Y20L	MMH-Y20T	LS	0.18 (4.5)	0.22 (5.5)	0.28 (7.0)	0.35 (9.0)	0.35 (9.0)	0.47 (12.0)
FRL-3	MMH-Y30L	MMH-Y30T	HM	0.12 (3.0)	0.12 (3.0)	0.16 (4.0)	0.16 (4.0)	0.16 (4.0)	0.16 (4.0)
FRL-4W/4Z	MMH-Y40L	MMH-Y40T	TS	0.20 (5.0)	0.20 (5.0)	0.28 (7.0)	0.28 (7.0)	0.28 (7.0)	0.41 (10.5)
FRL-4A	MMH-Y50L	MMH-Y50T	RM	0.09 (2.3)	0.11 (2.8)	0.14 (3.5)	0.18 (4.5)	0.18 (4.5)	0.24 (6.0)
FRL-5	MMH-Y60L	MMH-Y60T	H1	1.06 (27.0)	1.30 (33.0)	1.77 (45.0)	1.97 (50.0)	1.97 (50.0)	2.48 (63.0)
			HS1	0.79 (20.0)	0.94 (24.0)	1.38 (35.0)	1.57 (40.0)	1.57 (40.0)	1.97 (50.0)
			H2	2.13 (54.0)	2.60 (66.0)	3.54 (90.0)	3.94 (100.0)	3.94 (100.0)	4.96 (126.0)
			HS2	1.57 (40.0)	1.89 (48.0)	2.76 (70.0)	3.15 (80.0)	3.15 (80.0)	3.94 (100.0)

Spacers

To convert individual Filter, Regulator and Lubricators into combination units without mounting brackets. Seals included.

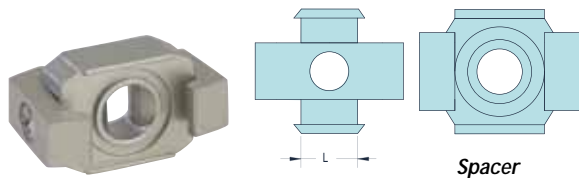

Series	Part No.	"L" Dimension
FRL-1	MMH-Y10	0.32 (8.1)
FRL-2	MMH-Y20	0.41 (10.4)
FRL-3	MMH-Y30	0.44 (11.2)
FRL-4W/4Z	MMH-Y40	0.55 (14.0)
FRL-4A	MMH-Y50	0.57 (14.5)
FRL-5	MMH-Y60	0.61 (15.5)

MAXIMUM
Value. ←
→ Performance.

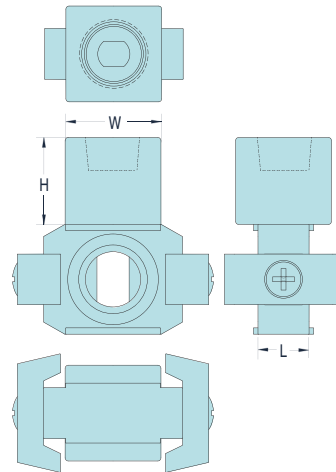

Spacers with Auxiliary Port

Provides parallel port between components.



MMH-Y21-N01

FRL Series	Spacer with Port	Spacer with L Bracket & Port	Spacer with T Bracket & Port	L	Dimension H	W
FRL-2	MMH-Y21-N01 (1/8")	MMH-Y21L-N01 (1/8")	MMH-Y21T-N01 (1/8")	0.41 (10.4)	0.69 (17.5)	0.76 (19.3)
	MMH-Y21-N02 (1/4")	MMH-Y21L-N02 (1/4")	MMH-Y21T-N02 (1/4")	0.41 (10.4)	0.69 (17.5)	0.76 (19.3)
FRL-3	MMH-Y31-N01 (1/8")	MMH-Y31L-N01 (1/8")	MMH-Y31T-N01 (1/8")	0.44 (11.2)	0.64 (16.3)	0.75 (19.1)
	MMH-Y31-N02 (1/4")	MMH-Y31L-N02 (1/4")	MMH-Y31T-N02 (1/4")	0.44 (11.2)	0.64 (16.3)	0.75 (19.1)
FRL-4W/4Z	MMH-Y41-N02 (1/4")	MMH-Y41L-N02 (1/4")	MMH-Y41T-N02 (1/4")	0.55 (14.0)	0.71 (18.0)	0.94 (23.9)
	MMH-Y41-N03 (3/8")	MMH-Y41L-N03 (3/8")	MMH-Y41T-N03 (3/8")	0.55 (14.0)	0.71 (18.0)	0.94 (23.9)
FRL-5	MMH-Y61-N03 (3/8")	MMH-Y61L-N03 (3/8")	MMH-Y61T-N03 (3/8")	0.61 (15.5)	0.79 (20.1)	1.18 (30.0)
	MMH-Y61-N04 (1/2")	MMH-Y61L-N04 (1/2")	MMH-Y61T-N04 (1/2")	0.61 (15.5)	0.79 (20.1)	1.18 (30.0)

T & L Brackets

L brackets are included with the purchase of combination FRLs, to convert to T, use T bracket only. If no bracket is furnished, use T or L bracket with MMH-YXX spacer (ordered separately).

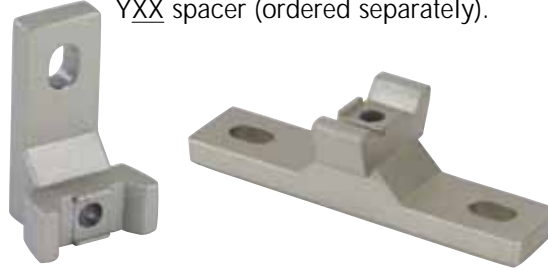
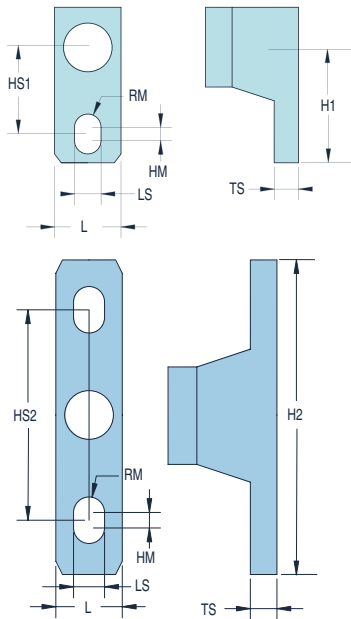

FRL Series	L Bracket Part No.	T Bracket Part No.
1	MMH-B110L	MMH-B110T
2	MMH-B210L	MMH-B210T
3	MMH-B310L	MMH-B310T
4W/4Z	MMH-B410L	MMH-B410T
4A	MMH-B510L	MMH-B510T
5	MMH-B610L	MMH-B610T

	MMH-B110T	MMH-B210T	MMH-B310T	MMH-B410T	MMH-B510T	MMH-B610T
Dim. MMH-B110L	MMH-B210L	MMH-B310L	MMH-B410L	MMH-B510L	MMH-B610L	
HS1	0.79 (20.1)	1.89 (48.0)	2.76 (70.0)	3.15 (80.0)	3.15 (80.0)	3.94 (100.0)
HS2	1.58 (40.1)	0.94 (24.0)	1.38 (35.0)	1.57 (40.0)	1.57 (40.0)	1.97 (50.0)
L	0.48 (12.2)	0.59 (15.0)	0.63 (16.0)	0.87 (22.0)	0.87 (22.0)	0.91 (23.0)
LS	0.18 (4.6)	0.22 (5.5)	0.28 (7.0)	0.35 (9.0)	0.35 (9.0)	0.47 (12.0)
HM	0.20 (5.1)	0.12 (3.0)	0.16 (4.0)	0.16 (4.0)	0.16 (4.0)	0.16 (4.0)
TS	0.20 (5.1)	0.20 (5.0)	0.28 (7.0)	0.28 (7.0)	0.28 (7.0)	0.41 (10.5)
RM	0.90 (22.9)	0.11 (2.8)	0.14 (3.5)	0.18 (4.5)	0.18 (4.5)	2.36 (6.0)
H1	0.61 (15.5)	0.65 (16.5)	0.89 (22.6)	0.99 (25.1)	0.99 (25.1)	1.24 (31.5)
H2	1.21 (30.7)	1.30 (33.0)	1.77 (45.0)	1.97 (50.0)	1.97 (50.0)	2.48 (63.0)

Replacement Bowls

All metal bowls come complete with a sight glass.

Filter	Poly. Bowl with Manual Drain	Poly. Bowl with Auto Drain	Metal Bowl with Manual Drain	Metal Bowl with Auto Drain
MMF-1 Series	27055-1	---	---	---
MMF-2 Series	27055-2	27055-2-A	27059-2	27059-2-A
MMF-3 Series	27056-3*	27056-3-A*	27059-3	27059-3-A
MMF-4 Series	27056-4*	27056-4-A*	27059-4	27059-4-A
MMF-5 Series	27056-5*	27056-5-A*	27059-5	27059-5-A

Lubricator	Poly. Bowl	Metal Bowl
MML-1 Series	27057-1	---
MML-2 Series	27057-2	27060-2
MML-3 Series	27058-3*	27060-3
MML-4 Series	27058-4*	27060-4
MML-5 Series	27058-5*	27060-5

* Comes standard with metal shield.





NEW! MAXIMATIC® MOUNTING HARDWARE & ACCESSORIES



Replacement Mounting Hardware for Regulators & Stacked Filter-Regulators

Brackets are included with the purchase of these components.

Regulator	Bracket Part No.
MMR-1N/MMFRS-1N	MMH-B120
MMR-2P/2Q	MMH-B220
MMFRS-2P/2Q	MMH-B220
MMR-3Q/3W	MMH-B320
MMFRS-3Q/3W	MMH-B320
MMR-4W/4Z/4A	MMH-B420
MMFRS-4W/4Z/4A	MMH-B420
MMR-5B	MMH-B420
MMFRS-5B	MMH-B420

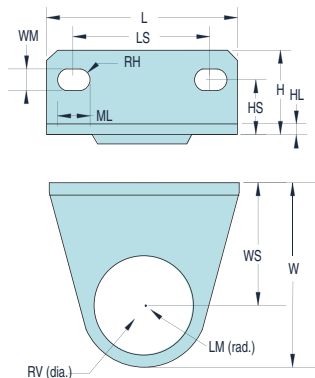

Dim.	MMH-B120	MMH-B220	MMH-B320	MMH-B420
L	1.57 (40.0)	2.17 (55.0)	2.09 (53.0)	2.76 (70.0)
LS	1.10 (28.0)	1.34 (34.0)	1.57 (40.0)	2.13 (54.0)
H	0.67 (17.0)	1.38 (35.0)	0.85 (21.5)	1.06 (27.0)
HS	0.43 (11.0)	0.75 (19.0)	0.55 (14.0)	0.71 (18.0)
W	1.49 (37.8)	1.97 (50.0)	2.52 (64.0)	3.12 (79.2)
WS	0.98 (25.0)	1.18 (30.0)	1.55 (39.0)	1.94 (49.2)
RV	0.81 (20.5)	1.32 (33.5)	1.67 (42.5)	2.07 (52.5)
LM	0.48 (12.3)	0.79 (20.0)	0.98 (25.0)	1.18 (30.0)
ML	0.26 (6.5)	0.21 (5.4)	0.26 (6.5)	0.33 (8.5)
WM	0.18 (4.5)	0.21 (5.4)	0.26 (6.5)	0.33 (8.5)
RH	0.09 (2.3)	0.11 (2.7)	0.13 (3.3)	0.17 (4.3)
HL	0.08 (2.0)	0.09 (2.3)	0.09 (2.3)	0.09 (2.3)



Mounting Hardware for Lubricators & Filters

No brackets are furnished with these components. Comes with hardware to mount bracket to MMF/MML.

Filter/ Lubricator	Bkt. Mtg. Thread	Bracket Part No.
MMF-2P	M4	MMH-B240
MML-2P	M4	MMH-B240
MMF-3	M4	MMH-B340
MML-3	M4	MMH-B340
MMF-4Z/4W	M5	MMH-B440
MML-4Z/4W	M5	MMH-B440
MMF-4A	M5	MMH-B540
MML-4A	M5	MMH-B540
MMF-5	M6	MMH-B640
MML-5	M6	MMH-B640

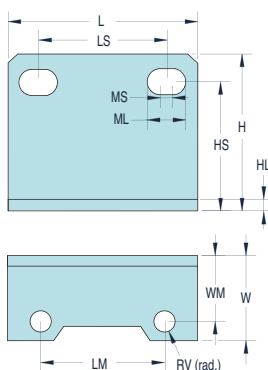

Dim.	MMH-B240	MMH-B340	MMH-B440	MMH-B540	MMH-B640
L	1.57 (40.0)	2.09 (53.0)	2.76 (70.0)	2.76 (70.0)	3.54 (90.0)
LS	1.06 (27.0)	1.57 (40.0)	2.13 (54.0)	2.13 (54.0)	2.60 (66.0)
H	1.30 (33.0)	1.53 (39.0)	1.85 (47.0)	1.85 (47.0)	2.52 (64.0)
HS	1.06 (27.0)	1.26 (32.0)	1.50 (38.0)	1.50 (38.0)	2.05 (52.0)
W	0.71 (18.0)	0.89 (22.5)	1.24 (31.5)	1.24 (31.5)	1.69 (43.0)
RV	0.18 (4.5)	0.18 (4.5)	0.22 (5.5)	0.22 (5.5)	0.26 (6.5)
LM	1.02 (26.0)	1.38 (35.0)	1.85 (47.0)	1.85 (47.0)	2.36 (60.0)
MS	0.12 (3.0)	0.06 (1.5)	0.08 (2.0)	0.08 (2.0)	0.08 (2.0)
ML	0.33 (8.4)	0.32 (8.0)	5.12 (13.0)	5.12 (13.0)	5.12 (13.0)
WM	0.21 (5.4)	0.26 (6.5)	0.43 (11.0)	0.43 (11.0)	0.43 (11.0)
HL	0.09 (2.3)	0.09 (2.3)	0.09 (2.3)	0.09 (2.3)	0.13 (3.2)

1/8" NPT Filter



1/8" NPT hex nipple with 40 micron filter / strainer, can be used as a muffler.

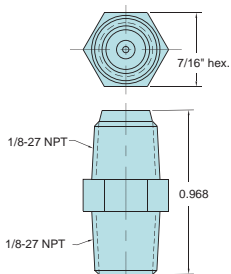

Part No.	Description
9002-01	1/8" NPT Filter

Muffler



The 3849-1 muffler is constructed of durable polyethylene with a 1/8" NPT male thread.

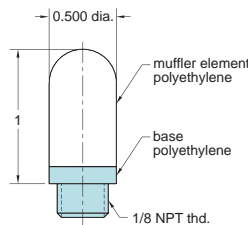

Part No.	Description
3849-1	Muffler

Filter Elements

All Maximatic filters come standard with a 25 micron sintered brass filter element and baffle, however 5 micron filters are also available. Add "-F5" to the end of the filter Part Number for 5 micron. Replacement filters with baffles are also offered below.

Filter Series	5 micron	25 micron
MMF-1	27021	27050
MMF-2	27022	27051
MMF-3	27023	27052
MMF-4	27024	27053
MMF-5	27025	27054



Gauge measures pneumatic system pressure. Stud mounted.



Range: Scale reading up to 160 psig/11 bar. See chart.

Construction: Steel case (nickel-plated on PG-101-NP). Plastic face. Dial shows two ranges; psig in black, bars in red. Built-in pressure snubber.

Ports: Connection located at rear is double threaded O.D. - male thread 1/8" NPT

Mounting: Stud mount using 1/8" NPT center stud

Pressure Gauges

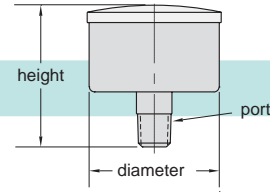

Part No.	Diameter	Height	Port	Range	
				psig	Bar
PG-10-30J*	1"	1.003"	1/16" NPT	0 to 30	0 to 2
PG-10-60J*	1"	1.003"	1/16" NPT	0 to 60	0 to 4
PG-10-160J*	1"	1.003"	1/16" NPT	0 to 160	0 to 11
PG-15-30P	1.5"	1.540"	1/8" NPT	0 to 30	0 to 2
PG-15-60P	1.5"	1.540"	1/8" NPT	0 to 60	0 to 4
PG-101-BK*	1.625"	1.670"	1/8" NPT	0 to 100	0 to 6.9
PG-101-NP*	1.625"	1.670"	1/8" NPT	0 to 100	0 to 6.9
PG-15-160P	1.5"	1.540"	1/8" NPT	0 to 160	0 to 11
PG-20-30Q	2"	1.680"	1/4" NPT	0 to 30	0 to 2
PG-20-60Q	2"	1.680"	1/4" NPT	0 to 60	0 to 4
PG-20-160Q	2"	1.680"	1/4" NPT	0 to 160	0 to 11

* I.D. - tapped for #10-32 fitting

Vacuum Gauge

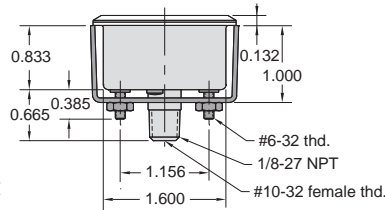
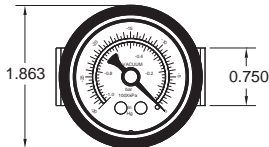

Gauge measures pneumatic vacuum pressure. Mounting bracket included.

Range: Scale reading from 0 to 30 in.Hg. and 0 to -1 bar

Construction: Nickel-plated steel case. Plastic face. Dial shows two ranges; Hg in black, bars in red. Built-in pressure snubber.

Ports: Connection located at rear is double threaded O.D. - male thread 1/8" NPT I.D. - tapped for #10-32 fitting

Mounting: Stud mount using 1/8" NPT center stud or panel mount using the zinc plated steel bracket supplied.

Part No.	Description
VG-30	Vacuum Gauge

Pressure Gauge

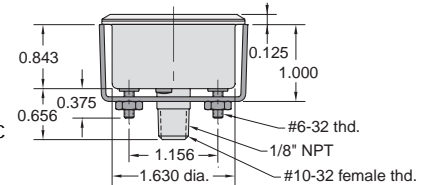
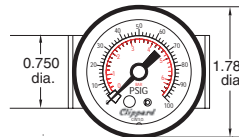

Gauge measures pneumatic system pressure. Mounting bracket included.

Input Pressure: Scale reading from 0 to 100 psig and 0 to 6.9 bar

Construction: Nickel-plated steel case. Plastic face. Dial shows two ranges; psig in black, bars in red. Built-in pressure snubber.

Ports: Connection located at rear is double threaded O.D. - male thread 1/8" NPT I.D. - tapped for #10-32 fitting

Mounting: With zinc plated steel bracket supplied

Part No.	Description
PG-100	Pressure Gauge



NEW! MAXIMATIC® REGULATORS

Flow Rate vs. Set Point Pressure @ 100 psig Supply Pressure

- Find the required flow rate in the graphs below.
- Determine the desired set point pressure.
- With a suggested pressure drop of <15 psig, determine which Regulator size provides the required flow rate.

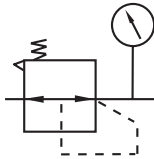

MMR-1 Series

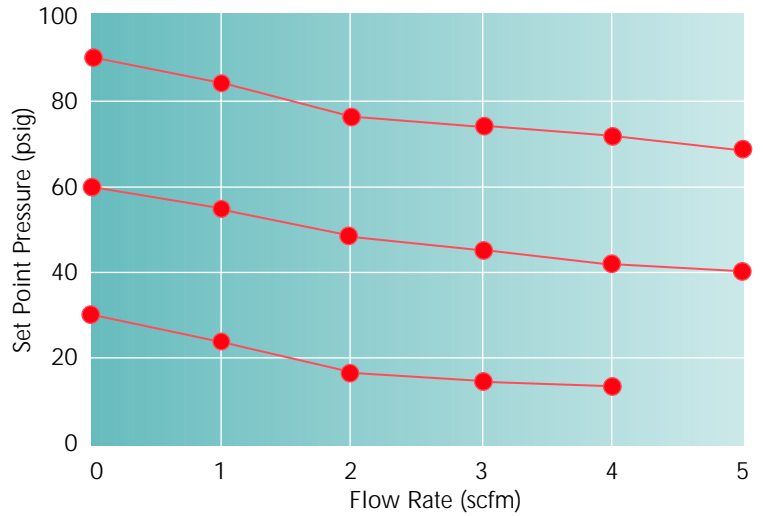

MMR-2 Series

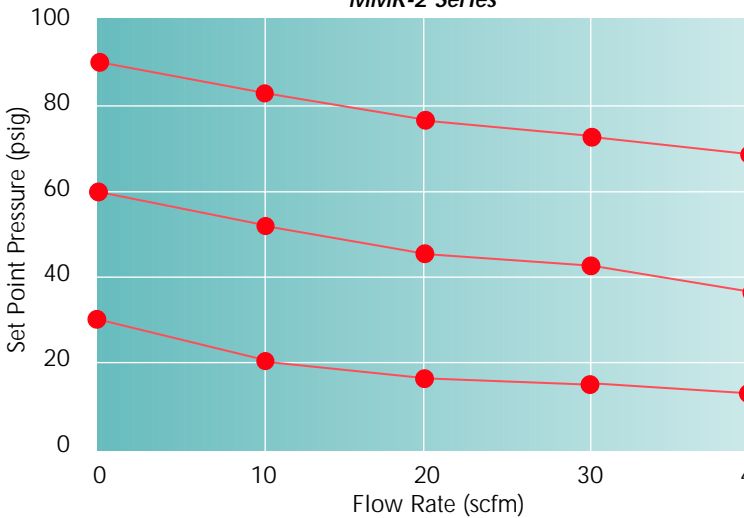

MMR-3 Series

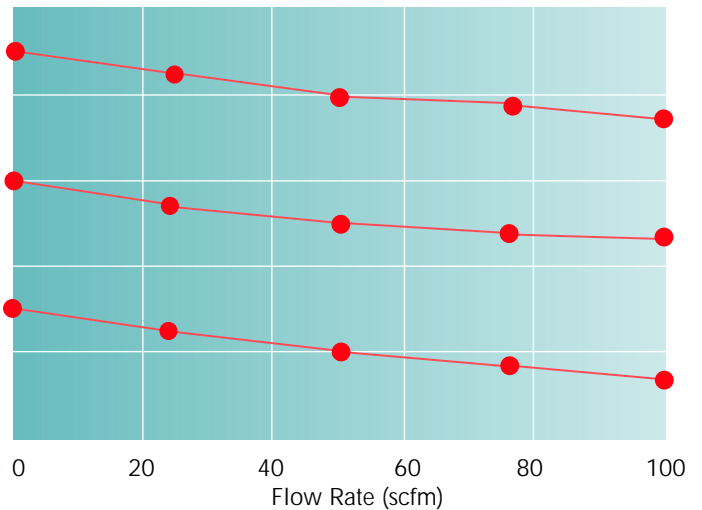

MMR-4 Series

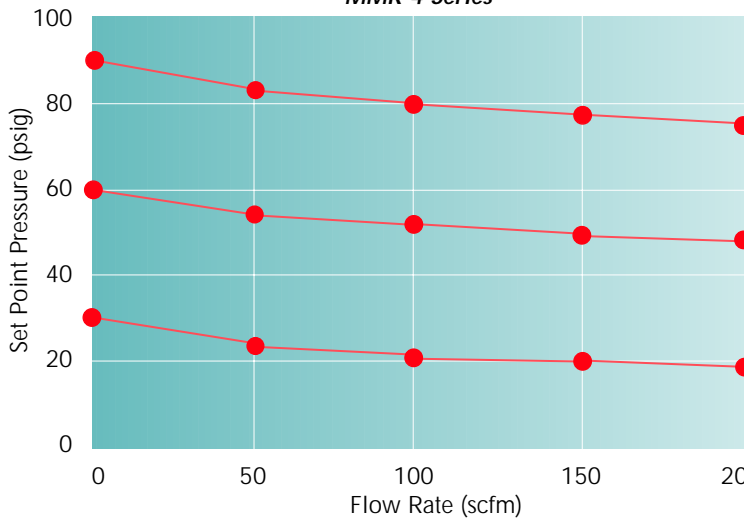

MMR-5 Series

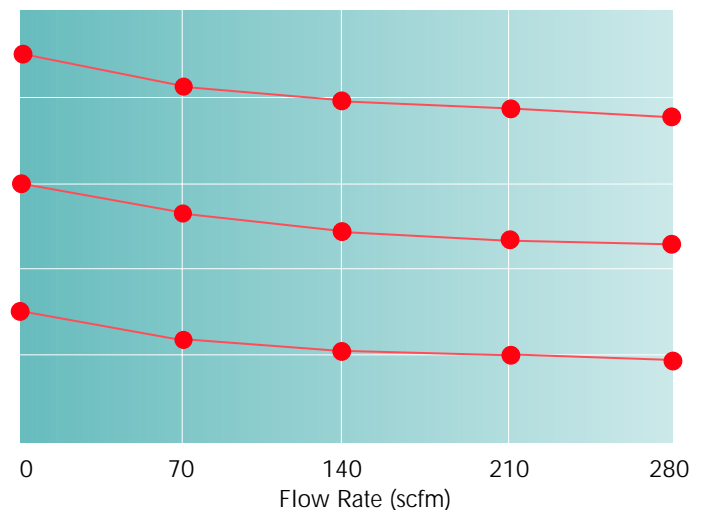

NEW! MAXIMATIC® FILTERS



Flow Rate vs. Set Pressure Drop @ 30 ●●●, 60 ●●● & 90 ●●● psig Supply Pressure



- Find the required flow rate in the graphs below.
- Determine the desired set point pressure.
- With a suggested pressure drop of <15 psig, determine which Filter size provides the required flow rate.

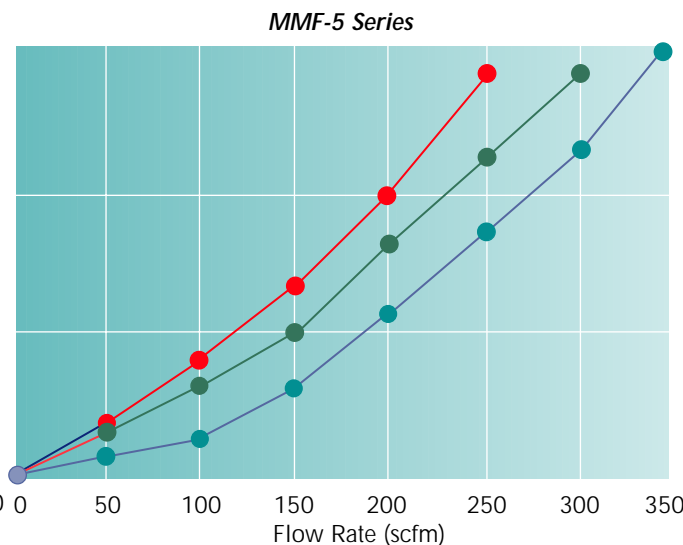
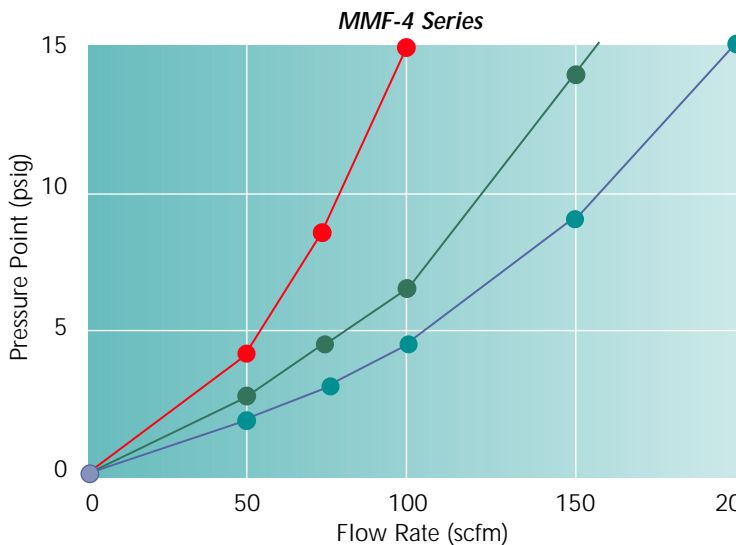
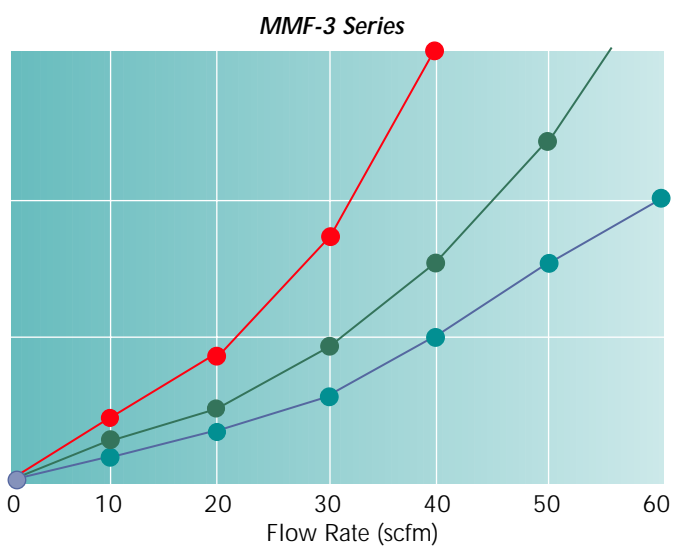
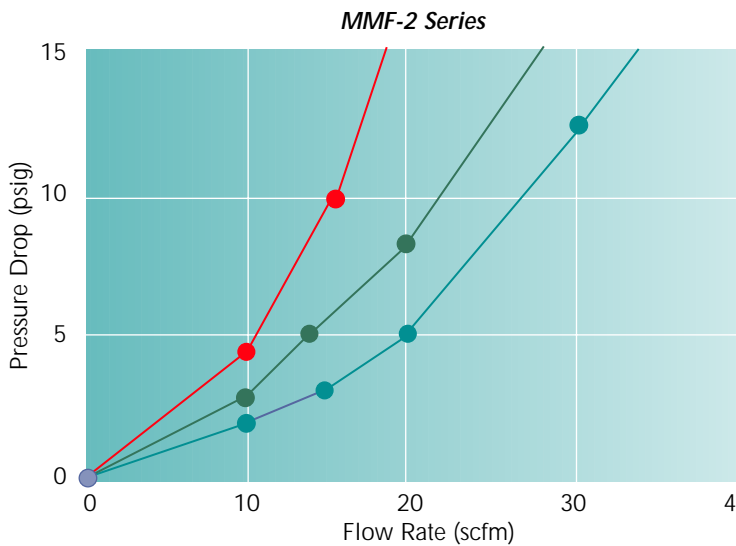
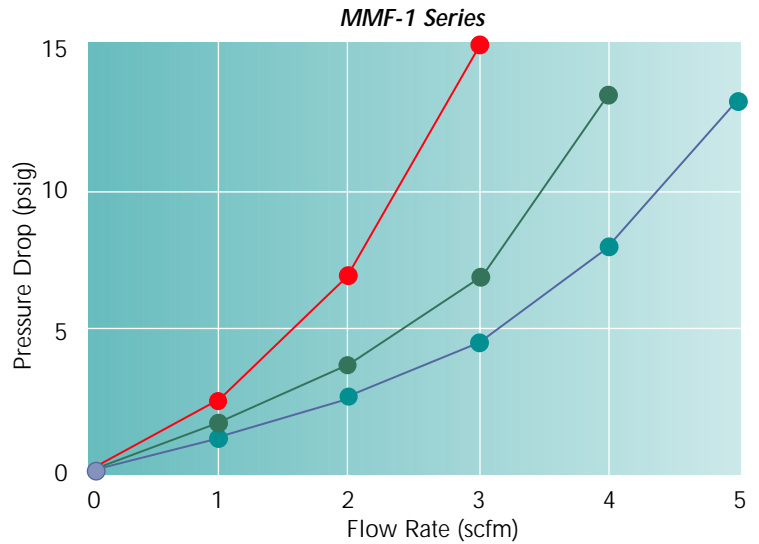
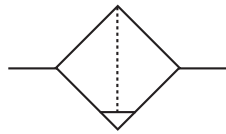



NEW! MAXIMATIC® STACKING FILTER-REGULATORS

Flow Rate vs. Set Point Pressure @ 100 psig Supply Pressure

- Find the required flow rate in the graphs below.
- Determine the desired set point pressure.
- With a suggested pressure drop of <15 psig, determine which Filter-Regulator size provides the required flow rate.

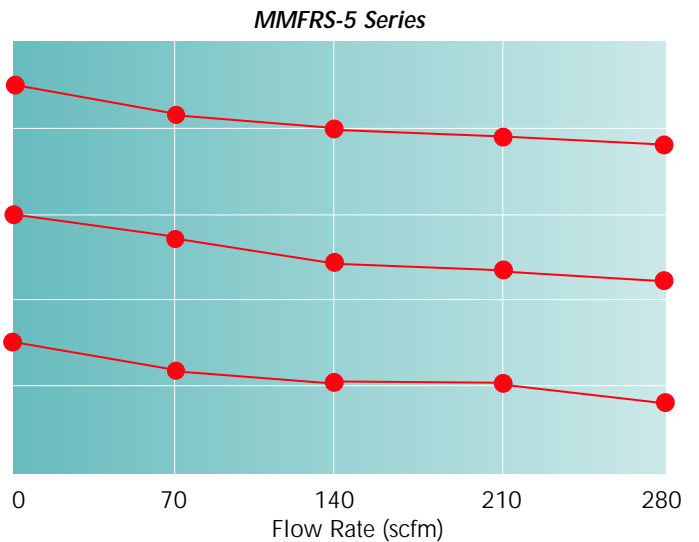
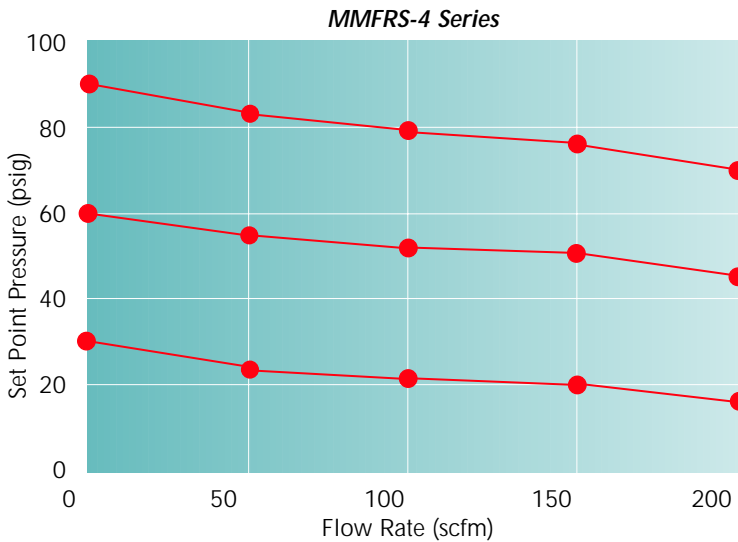
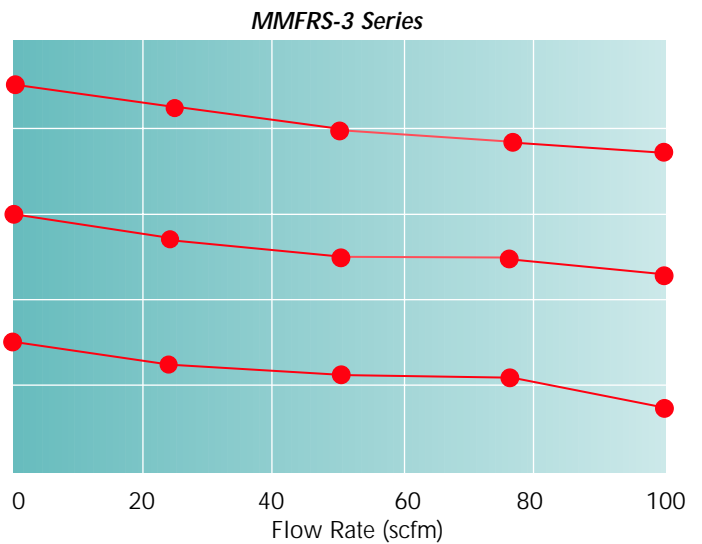
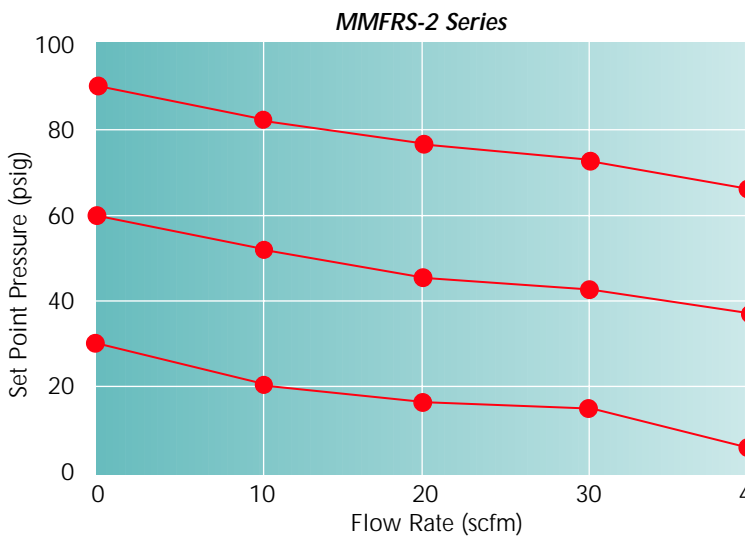
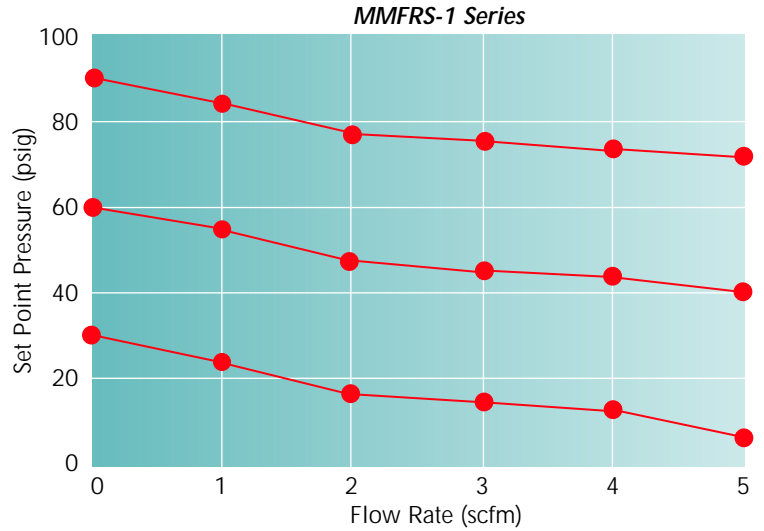
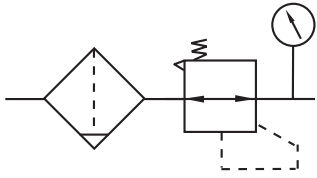

Flow Rate vs. Set Point Pressure @ 100 psig Supply Pressure

- Find the required flow rate in the graphs below.
- Determine the desired set point pressure.
- With a suggested pressure drop of <15 psig, determine which FRL size provides the required flow rate.

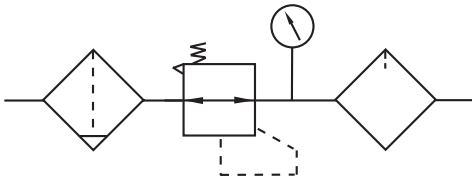

MMFRL-1 & MMFRLS-1 Series

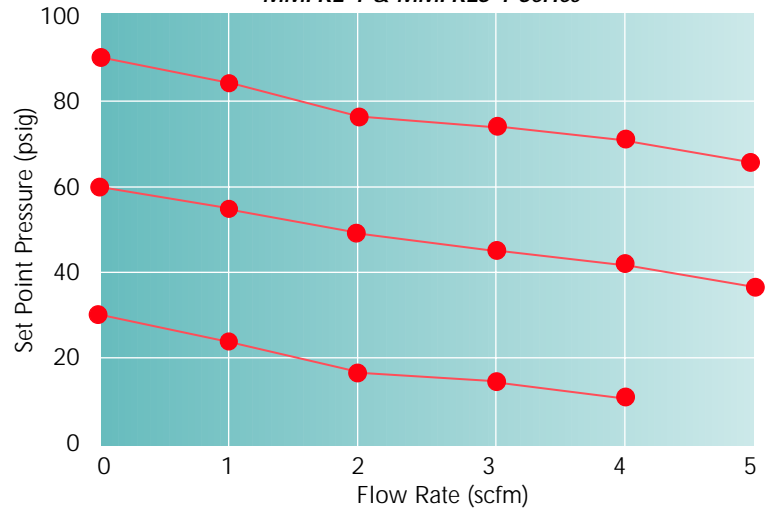

MMFRL-2 & MMFRLS-2 Series

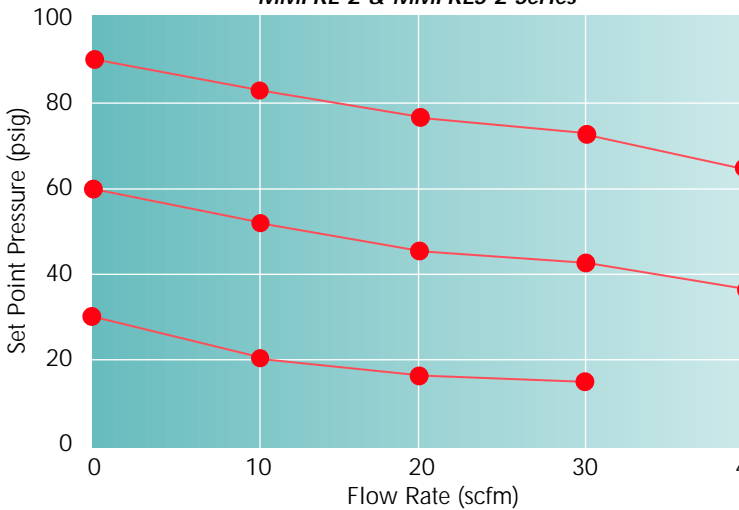

MMFRL-3 & MMFRLS-3 Series

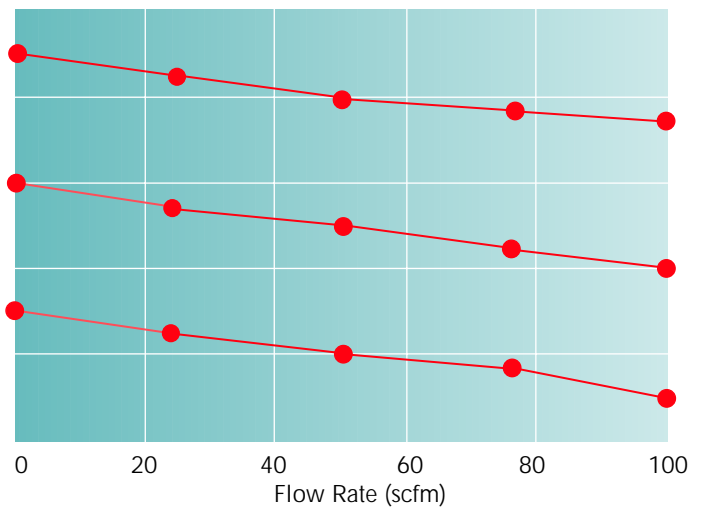

MMFRL-4 & MMFRLS-4

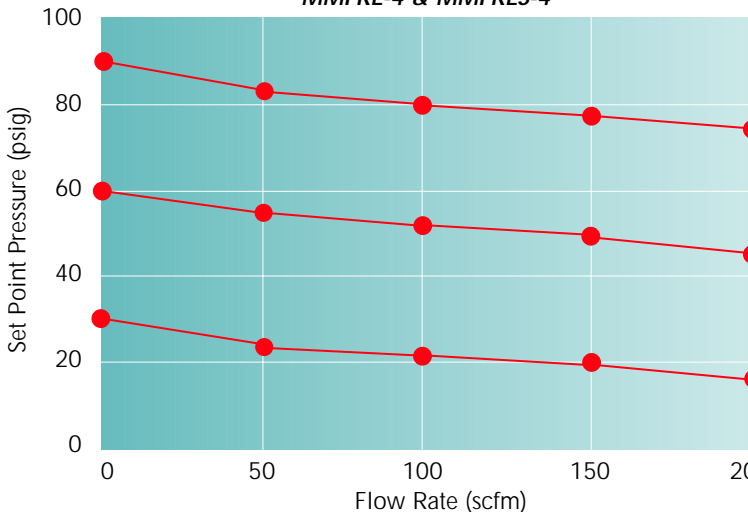

MMFRL-5 & MMFRLS-5 Series

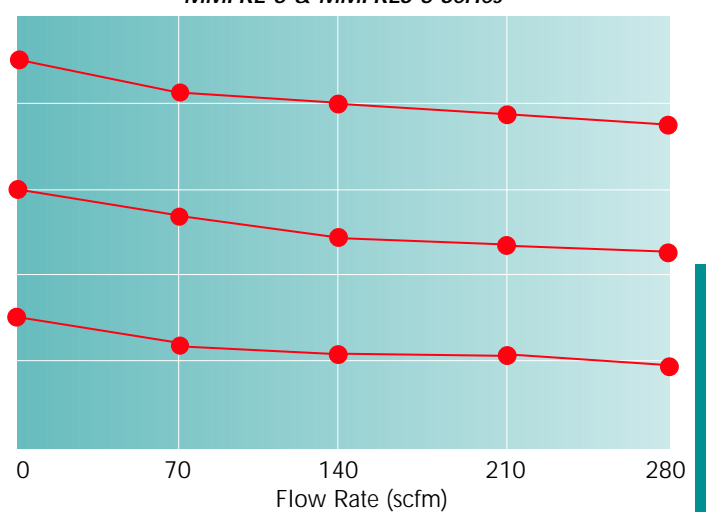



2-WAY & 3-WAY SLEEVE/SHUT-OFF VALVES

2 Position 2-Way or 3-Way Sleeve Valves

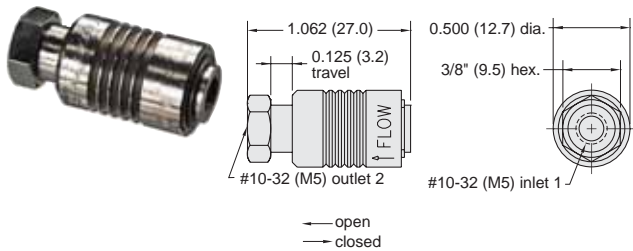

Medium: Air

Mounting: Inline or direct to fitting

Stem Travel: 1/8" (3.2)

Material: Nickel plated brass

Input Pressure: 150 psig/10 bar max.

Air Flow: 6.5 SCFM @ 50 psig; 11.8 SCFM @ 100 psig; 280 l/min @ 6 bar

Force to Actuate: Approx. 2.5 lbs

Part No.	Description
SLV-2	2 Position 2-Way Sleeve Valve, #10-32
SLV-2-M5	2 Position 2-Way Sleeve Valve, M5
SLV-3	2 Position 3-Way Sleeve Valve, #10-32
SLV-3-M5	2 Position 3-Way Sleeve Valve, M5

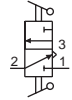

J-Series Sleeve Valves

Features

- Variety of inlet and outlet porting eliminates fittings
- No cross-over between inlet and exhaust ports
- Corrosion resistant electroless nickel plated brass body
- Anodized aluminum sleeve for corrosion resistance
- Smooth operation, low sliding friction
- Buna-N seals; (Fluorocarbon available)

Clippard J-Series sleeve valves with 1/8" NPT and 1/4" NPT ports offer large flow capability with a relatively short stroke in 2-way and 3-way valves, and no cross-over between inlet and exhaust on the 3-way models.

The JSLV-2 2-way valve and the JSLV-3 3-way valve combine high flow with small size. Unlike ball valves, sleeve valves require no space for a handle. They also provide flexibility in pipe connections and are available with either male or female threads or combinations of both.

The JSLV-2 and JSLV-3 valves feature a smooth opening stroke during which inlet air is directed to the outlet. During the closing stroke, in the opposite direction of travel, the outlet is closed from the inlet and in the JSLV-3 version, the outlet is then exhausted to atmosphere without the inlet ever being connected to exhaust.

Medium: Air, Water or Oil

Force to Actuate: Approx. 8 lbs

Input Pressure: 150 psig max.

Mounting: Inline or direct to fitting

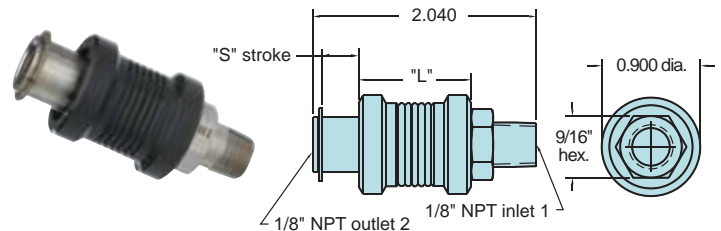
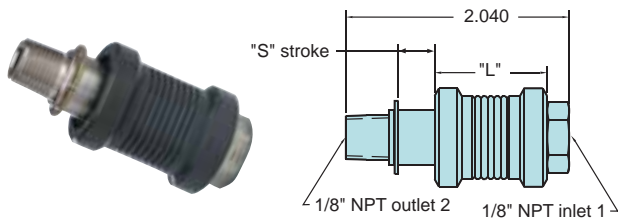

Air Flow: 1/8" NPT: 43 SCFM @ 100 psig

Air Flow: 1/8" NPT: 43 SCFM @ 100 psig

Order No.	Type	Inlet	"L"	"S"
JSLV-2-F2M2	2-Way	1/8 Female Pipe	1.155"	0.260"
JSLV-3-F2M2	3-Way	1/8 Female Pipe	1.030"	0.385"

Order No.	Type	Inlet	"L"	"S"
JSLV-2-M2F2	2-Way	1/8 Male Pipe	1.155"	0.260"
JSLV-3-M2F2	3-Way	1/8 Male Pipe	1.030"	0.385"

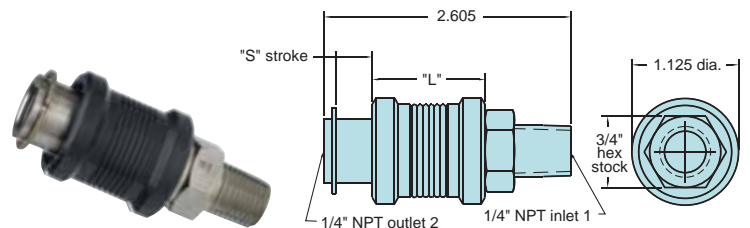
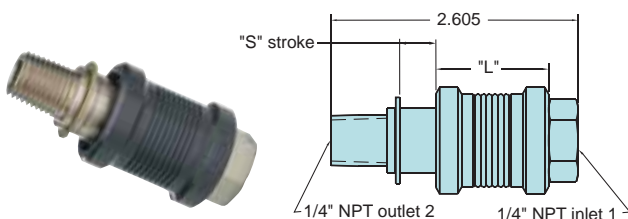

Air Flow: 1/4" NPT: 70 SCFM @ 100 psig

Air Flow: 1/4" NPT: 70 SCFM @ 100 psig

Order No.	Type	Inlet	"L"	"S"
JSLV-2-F4M4	2-Way	1/4 Female Pipe	1.325"	0.305"
JSLV-3-F4M4	3-Way	1/4 Female Pipe	1.190"	0.460"

Order No.	Type	Inlet	"L"	"S"
JSLV-2-M4F4	2-Way	1/4 Male Pipe	1.325"	0.305"
JSLV-3-M4F4	3-Way	1/4 Male Pipe	1.190"	0.460"

Miniature Pressure Regulators

Regulators are offered in either relieving or non-relieving versions. The relieving design maintains a constant pressure output even when downstream conditions change. As downstream pressure increases due to reduced flow, this increased pressure overcomes the regulator piston and the pressure is relieved to atmosphere to maintain a constant output pressure.

The non-relieving regulator does not automatically compensate for changes in downstream flow or pressure. There is no vent to atmosphere, as in a relieving type regulator, and the output pressure can increase due to a downstream flow.

Plunger-Type Pressure Regulators

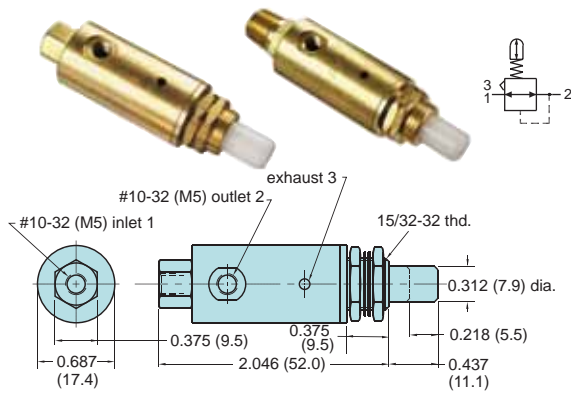

Plunger Travel: 7/32" Force For Full Stem Travel: 25 lb nominal

Operation: As plunger is depressed pressure increases proportionally to the travel; when plunger is released the input is closed and the output pressure is exhausted to atmosphere

Range (psig/bar)*	#10-32	1/8" NPT	M5
0-20/1.4	MAR-1C-2	MAR-1CP-2	MAR-1C-2-M5
0-30/2.1	MAR-1C-3	MAR-1CP-3	MAR-1C-3-M5
0-40/2.8	MAR-1C-4	MAR-1CP-4	MAR-1C-4-M5
0-50/3.4	MAR-1C-5	MAR-1CP-5	MAR-1C-5-M5
0-60/4.1	MAR-1C-6	MAR-1CP-6	MAR-1C-6-M5
0-70/4.8	MAR-1C-7	MAR-1CP-7	MAR-1C-7-M5
0-100/6.9	MAR-1C	MAR-1CP	MAR-1C-M5

* Outlet pressure is based on 7/32" stem travel. If stem is depressed further, the outlet pressure will increase.

Replacement Air Filter with Element



Medium: Air Only **Filtration:** 35 micron

Input Pressure: 0-250 psig max. **Material:** Brass

Air Flow: 5.0 SCFM @ 50 psig; 9.0 SCFM @ 100 psig

Mounting: Direct or inline

Cleanout: Press clean-out valve stem periodically to remove accumulated water. For complete cleaning, filter body unscrews at point "A" without disturbing piping. DO NOT DISASSEMBLE UNDER PRESSURE. Remove screw and filter element to clean or replace

- Panel mounting permits unit to be located with other controls on a control console or panel board for pilot operation of larger regulators or for remote control; mounting nuts and lockwashers furnished
- Small, compact - ideal for mounting on individual jigs and fixtures as well as in control circuits

Medium: Air

Materials: Brass body, Buna-N seals, stainless steel stem and spring

Air Flow: 3 SCFM @ 50 psig; 5 SCFM @ 100 psig; 120 l/min. @ 6 bar

Input Pressure: 300 psig/21 bar max.

Mounting: 15/32-32 thread. Nuts and lockwashers furnished

Adjustment: By means of a knob with micro-adjustment (40 pitch thd.)

Adjustable Pressure Regulators

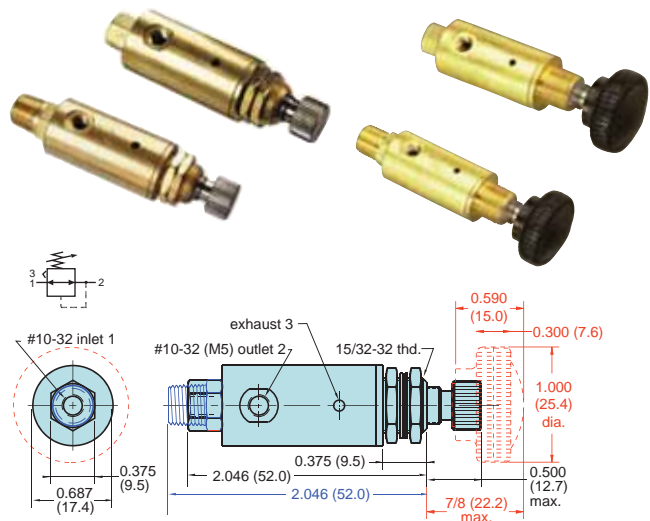

Range (psig/bar)	#10-32	Knob	1/8" NPT	Non-Relieving	M5
0-20/1.4	MAR-1-2	MAR-1K-2	MAR-1P-2	MAR-1NR-2	MAR-1-2-M5
0-30/2.1	MAR-1-3	MAR-1K-3	MAR-1P-3	MAR-1NR-3	MAR-1-3-M5
0-40/2.8	MAR-1-4	MAR-1K-4	MAR-1P-4	MAR-1NR-4	MAR-1-4-M5
0-50/3.4	MAR-1-5	MAR-1K-5	MAR-1P-5	MAR-1NR-5	MAR-1-5-M5
0-60/4.1	MAR-1-6	MAR-1K-6	MAR-1P-6	MAR-1NR-6	MAR-1-6-M5
0-70/4.8	MAR-1-7	MAR-1K-7	MAR-1P-7	MAR-1NR-7	MAR-1-7-M5
0-100/6.9	MAR-1	MAR-1K	MAR-1P	MAR-1NR	MAR-1-M5

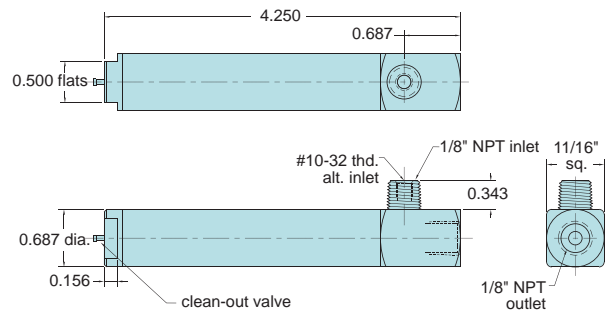

Part No.	Description
MAF-1	Replaceable Air Filter with Element
12382	Low Pressure Drop, Concentric, Chemically-Inert 35-micron Filter Elements



REGULATORS, FILTERS & INDICATORS



Pressure Regulator

R-701 is a self-relieving, adjustable pressure regulator with multiple output ports. Pressure can be piped directly from ports 2, 4, 6 and 8. Eliminates need for additional fittings. Unused output ports should be plugged.

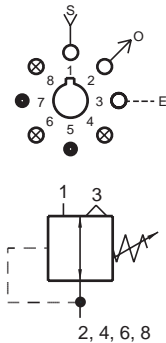

- Multiple porting speeds piping
- Knurled knob for fast, accurate adjustments - no tools needed

Flow: 12 scfm @ 100 psig; 340 l/min @ 6.9 bars
Temperature: 32° to 180° F
Working Pressure: 0 to 150 psig; 0 to 10.3 bars

Part No.	Description
R-701	Pressure Regulator



Filter

R-801 is a 25 micron filter with multiple outlets at ports 2, 3, 4, 6, 7 and 8 to minimize need for fittings. Port 5 is a drain and should be plugged; however, when the valve is mounted vertically port 5 can be tubed to a drain. Unused ports should be plugged.

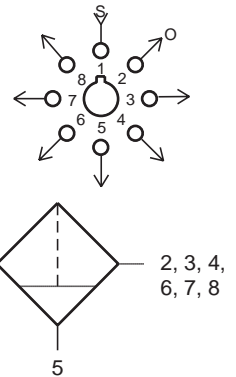

- Multiple porting speeds piping
- Clean out port for easy maintenance
- Protects system - assures proper functioning
- Replaceable filter element (Part No. R-801-14)

Flow: 12 scfm @ 100 psig; 339 l/min @ 6.9 bars
Temperature: 32° to 180° F
Working Pressure: 0 to 150 psig; 0 to 10.3 bars

Part No.	Description
R-801	Filter

Multi-Pin Air Indicator

Plunger type (when extended 7-pin color display signals "on")

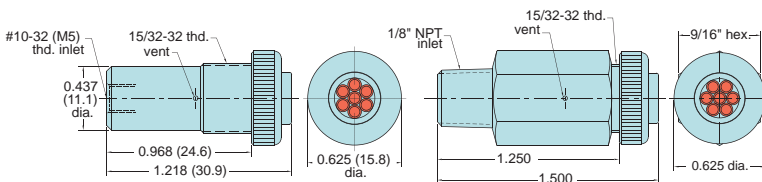

Medium: Air Only

Input Pressure: 150 psig/1-10 bar max.

Minimum Actuation Pressure: 15 psig (approx)

Response: Approx. 10 ms @ 50 psig

Filtration: 40 micron recommended

Mounting: IND-3: Panel mount in hole. #15/32-32 nut and lockwasher provided; IND-3P: Direct mount into 1/8" NPT hole

Maximum Panel Thickness: 3/16" (4.8)



Part No.	Description
IND-3-(color)	Multi-Pin Air Indicator, #10-32
IND-3-M5-(color)	Multi-Pin Air Indicator, M5
IND-3P-(color)	Multi-Pin Air Indicator, 1/8" NPT

GN-Green, WH-White, RD-Red, YL-Yellow

Single Pin Air Indicator

Plunger type (when extended white pin display signals "on")

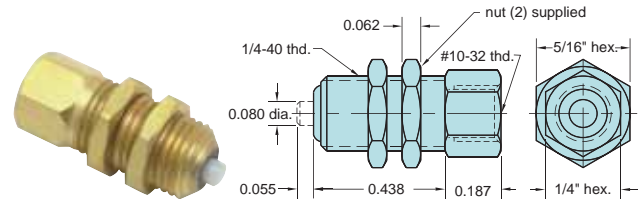

Part No.	Description
IND-1-WH	Single Pin Air Indicator

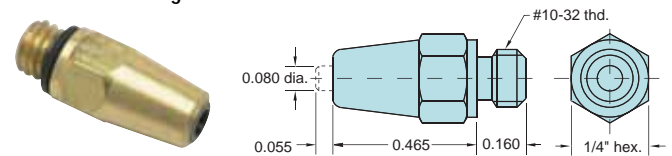

Part No.	Description
IND-1M-WH	Single Pin Air Indicator

Medium: Air Only

Input Pressure: 150 psig/1-10 bar max.

Minimum Actuation Pressure: 12 psig (approx)

Response: Approx. 10 ms @ 50 psig

Filtration: 40 micron recommended

Mounting: IND-1-WH: Panel mount 1/4 dia. hole. 1/4-40 thd. nuts provided. IND-1M-WH: Direct mount into 1/8" NPT hole

Maximum Panel Thickness: 3/16" (4.8)

